

1st Order Diffraction Efficiency, HD 1624 l/mm @ 871 nm

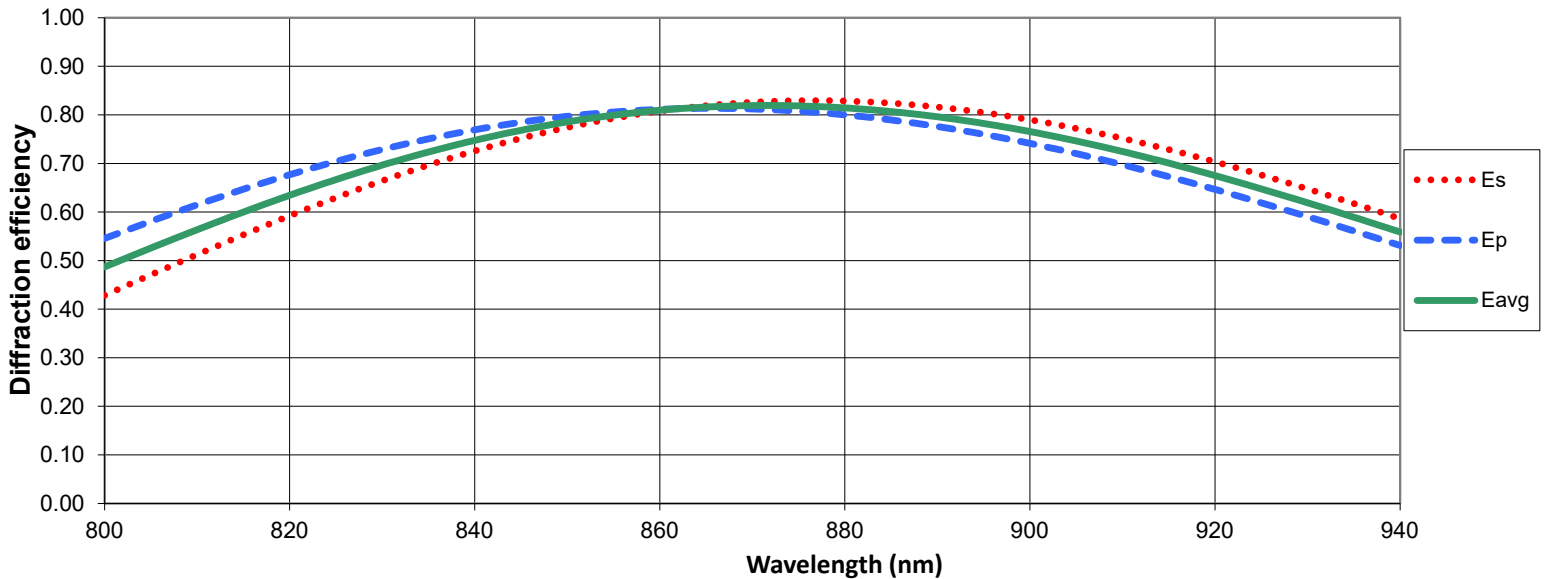

Diffraction efficiency curves are theoretical. Actual performance will vary slightly.
Includes: glass absorption data, adhesive absorption data, film absorption data, manufacturing tolerances.

| Specifications HD1624 l/mm @ 871 nm | |
|-------------------------------------|---|
| Spatial Frequency | 1624 l/mm +/- 0.5 l/mm |
| Wavelength Range | 800 to 940 nm |
| Center Wavelength | 871 nm |
| Angle of Incidence | 45° |
| Dimensions | 25.4 mm dia +0/-0.15 mm |
| Thickness | 3 mm +0.25/-0.25 mm |
| Clear Aperture | 19.4 mm dia +1/-0 mm |
| Polarization | Average |
| Surface Quality | 60/40 |
| Substrate | N-BK7 or equivalent |
| AR Coating | Yes |
| Grating Lines | Indicated by Mark on Edge |
| Wavefront | λ/5 RMS at 633 nm over any 25 mm diameter |

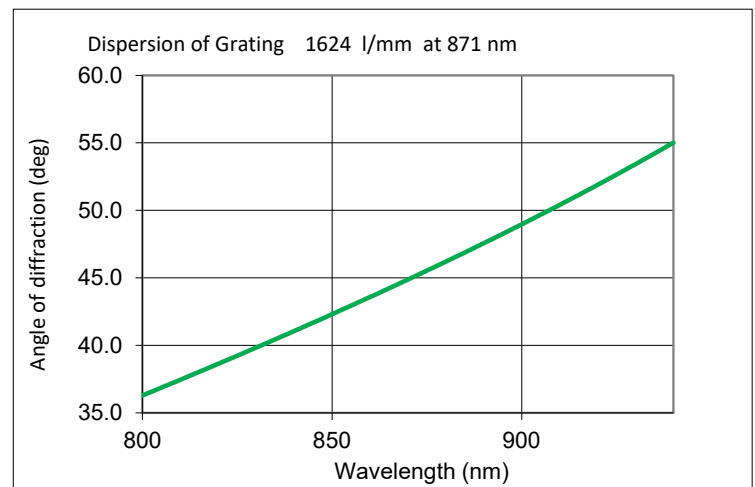
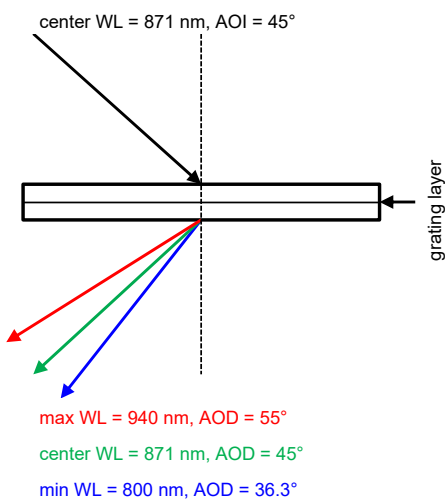
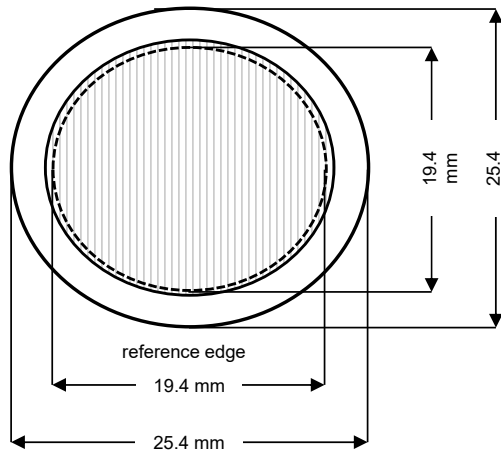

Cleaning, Handling, and Storage

Wasatch Photonics' Volume Phase Holographic Gratings, whether they are AR coated or not, can be easily be cleaned just as you would any other glass optic to remove fingerprints, dust, and contaminants. Use the standard optics cleaning method of "drop and drag". Gently wipe the grating with a clean, lint-free cloth/wipe using acetone or alcohol without much pressure; reagent-grade methanol or Windex may also be used. Do not use polishing compounds, abrasive materials, etc. Hard rubbing with such chemical or polishing compounds may damage the AR coating. AR coated surfaces will pass the "Scotch Tape" test.

Gratings may be stored or used at temperatures up to 100C and in cryogenic conditions at less than 100K.